

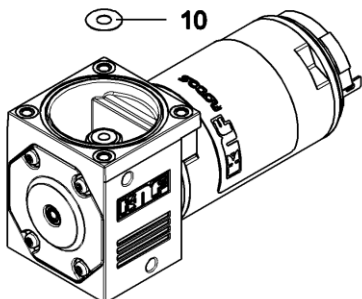

Viper Pump Disassembly and Cleaning Instructions

Drawings do not depict the orientation of the head depending on Viper model.
 Please note this before taking pump apart.

- 1 Outlet
- 2 Inlet
- 3 Connecting plate
- 4 Motor
- 5 Head plate
- 6 Intermediate plate

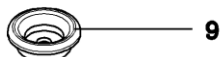
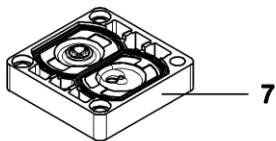
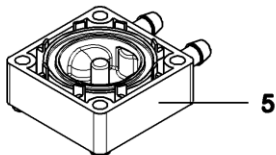
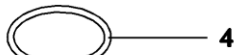
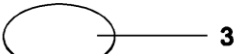
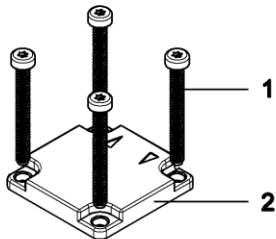
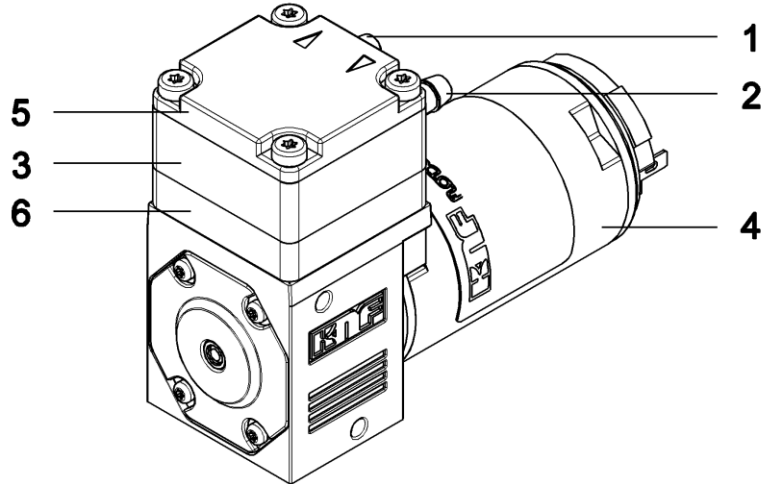

Disassembling the pump head exploded view

1. Loosen the four head screws (1) and remove the whole head.
2. Take the head plate (2) off.
3. Remove o-ring (4)
4. Remove the resonating diaphragm (3) Check if badly warped it might need replaced
5. Take connecting plate (5) off
6. Take the valve plate (6) out of the intermediate plate (7)
7. Check the diaphragm (8) and wipe off.
9. If replacing diaphragm (8) DO NOT LOOSE the washers (10) some pumps will have 1 or 2 depending on tolerance.